

DGC Service instruction 2" hose unit



MannTek

Quality, Health, Safety and Environment Policy

Our objectives are simple – no accidents, no occupational illness or work related accidents, no negative environmental impact and optimizing and continuously improving customer satisfaction wherever we operate.

Mariestad, February 22 2019



Markus Bäckström

What does this mean?

In our daily work to develop, sell, deliver and maintain our products this means to act as soon as we recognize a risk for:

- Delivery of products with insufficient technical quality
- Giving incorrect information
- Not complying with laws and regulations concerning our operation
- Causing negative environmental impact
- Causing occupational illness or accidents
- Not being able to keep promises on delivery terms (product and information)

To act, here means to point out the risk and to make sure we take a balanced decision to prevent what is undesired.

(This policy includes all that is traditionally covered in separate policies for quality, health, safety and environment)

HOSE UNIT 2" MATERIAL: AL, SS

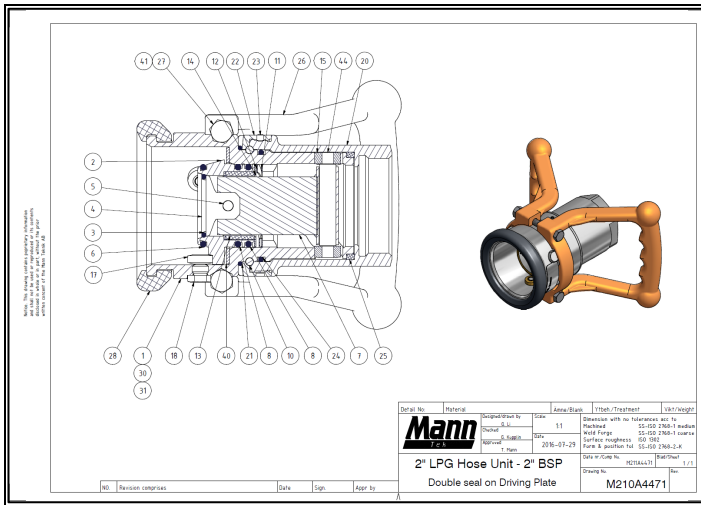

Hose unit with -71 O-rings

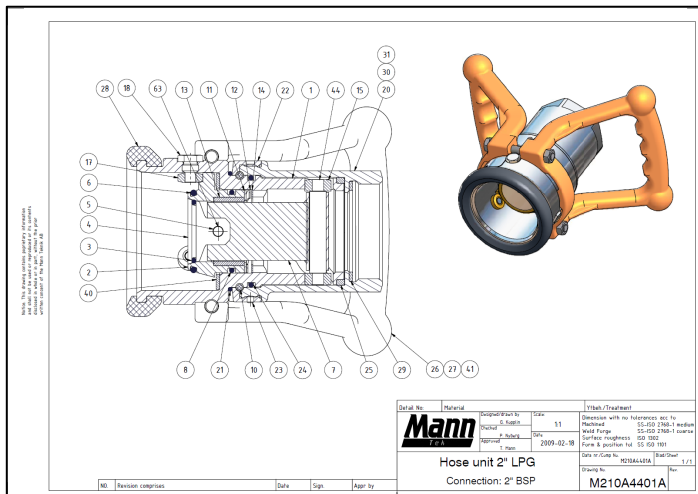

All hose units except ones with -71 O-ring

PERFORM A SERVICE:

If leaking

At a minimum once per year or more often if the application so requires.

Change of media

PARTS NEEDED FOR SERVICE:

Spare part kit and O-ring kit (see page 4)

TOOLS NEEDED FOR SERVICE:

Tool 001 O-ring tools

Hexagon wrench no.2

Tool 221LPG-4

Tool 265-3

Ø5 mm pin

Wrench 13 mm x2



Tool 221LPG-4



Hexagon wrench no.2



Ø5 mm pin



Tool 001



Tool 265-3

MAINTENANCE AND SERVICE INSTRUCTION



Always depressurize the system and rinse off the parts before beginning any maintenance work. Use protective goggles. Do not handle O-ring seals if the material appears charred, gummy or sticky.



Use tweezers and wear neoprene or PVC gloves. Do not touch adjacent parts with unprotected hands. Rinse off the parts once again before starting the “daily inspection”

DAILY INSPECTION

1. Inspect the coupling surface for cleanliness and corrosion.
2. Inspect the O-ring in the hose unit connection for serviceability and correct seating in the groove.
3. Inspect the hose unit swivel for free rotation.
4. Inspect the hose unit for mechanical damage and external signs of seizure.

REGULAR SERVICE

Regular service interval is very much depending on local regulations and application conditions. It is recommended practice to make the service on the hose unit at the same time as the service of the hose. According to branch standard that would be every 12 months.

The service procedure shall be as follows:

1. Replace all O-Rings.
2. Refill the hose unit ball bearing housing with grease.
3. Replace worn or damaged components.

Check the state of the connection surface and verify that it is clean before proceeding with the connection.

Couple the serviced hose unit to a usable tank unit and check for the correct operation of the valve actuating and bayonet locking mechanism. Couple and uncouple the unit(s) several times.

USE ONLY ORIGINAL MANNTEK SPARE PARTS FOR MAINTENANCE.

Spare part kit (S-M2-xx)

O-ring kit (O-M2-yy)

xx and yy means the material key according to the product catalogue. You will find it also as the 6th to 9th sign in the serial number (e.g. M210AxxyyA).



PLEASE NOTE!

Make sure that you are using the right type of O-rings and seals for the media you are using. We are using a standard silicone based grease for standard media, for special media please contact us.



Unscrew and remove the lock screw from the swivel ring.

Hexagon wrench No. 2



Mark the position of the swivel sleeve against the swivel ring. Remove the swivel sleeve from the swivel ring. Fixate the swivel ring with help of a $\varnothing 5$ mm pin. Unscrew the swivel sleeve from the ring.



Unscrew and remove the handle.

Wrench 13 mm x2



Put the hose unit on tool 221LPG-4 and turn it.



Remove the two rollers and the rolling shaft from the piston guide.

MannTek



Remove the driving plate packet from the coupling body.



Change O-ring (pos.21) for dust – protection. Use Fluorflon® grease on the new O-ring.

Tool 001



Remove and change the O-ring (pos.24) from the groove in the coupling body. Use Fluorflon® grease on the new part. Apply Fluorflon® grease on the balls for best possible swivel rotation.

A mounting sleeve is recommended to mount the o-ring. If no sleeve is available a plastic strip can be taped around the body to cover the cam curves

Tool 001



Check the rollers for easy rotation and wear. If needed change the three shafts (pos.18) and rollers (pos.17) to new ones.

Use Loctite® 2700 on the shafts and Cargo Fluor® to lubricate rollers.

Wrench

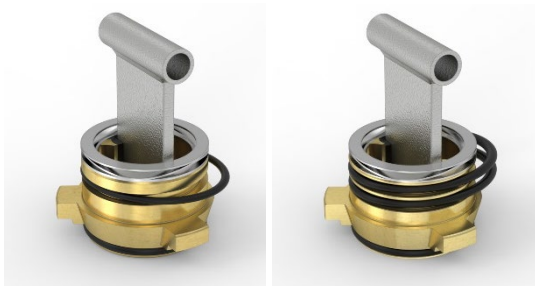

Change the O-ring (pos.8) on the driving plate back side. Use Fluorflon® grease on the O-ring.

Make sure that the O-ring doesn't get twisted when mounting.

Tool 001

O-ring (pos. 8) 2 pcs
when -71 O-rings

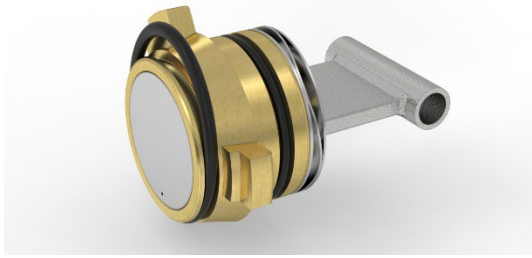

Make sure that the O-ring doesn't get twisted when mounting.

Tool 001



Tool 001

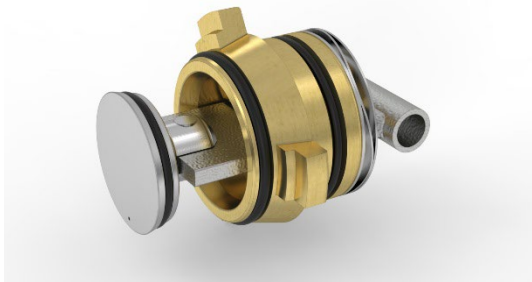

Mount the rolling shaft and the two rollers into the piston guide. If needed, mount at a lower position in the cam curve.



Apply a small amount of Cargo Fluor® on the rolling shaft as well as on the outside of the rollers.

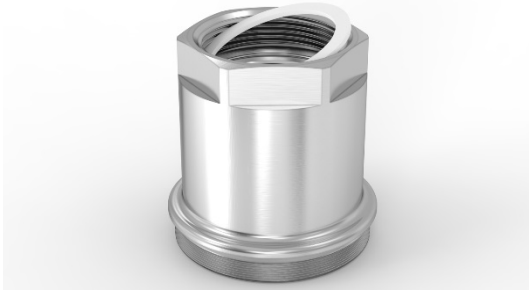

Wrench 13 mm



Ⓜ on the top of the thread on the sleeve. Then place the swivel sleeve over the coupling body and screw in the swivel sleeve until it is aligned with the marking. Screw the lock screw into the swivel ring.

Tool 265-3, Hexagon wrench 2 & Ø5mm pin



Perform a visual inspection ensuring that everything is in its place. Also do a test connection/disconnection with a tank unit that doesn't have any fluid inside. Finally, do a pressure test according to the test procedure described on page 9. If the coupling works alright you are ready to mount the hose unit on your hose again.

Loctite® is registered trademark of Henkel.

TEST PROCEDURE

After each service a pressure and tightness test of each coupling is mandatory.

If only the O-Ring kit is replaced a seat tightness test is enough.

The following test parameters are in accordance with EN12266 and EN14432:

| Test procedure | Test pressure | Acceptance criteria |
|---|---|---|
| Seat tightness test (Air) | 6 bar +/- 1 bar | No visually detectable leakage for the duration of the test |
| | Max 0,3 bar | |
| Shell tightness test (Water) (if applicable) |  1,5 x working pressure* | |

Table 1 – Test pressure

| Nominal size | Minimum test duration |
|-----------------|-----------------------|
| Up to DN 50 | 15 s |
| DN 65 to DN 150 | 60 s |

Table 2 – Minimum test duration

TEST PROCEDURE:

- Plug the hose unit with the appropriate end connection and fill it with the test media (e.g. air or water).
- Apply the test pressure specified in Table 1.
- Maintain the test pressure for the test duration specified in Table 2.
- Determine the leakage rate.
- Couple the serviced hose unit to a usable tank unit and test for leakage.

If a pressure test should be achieved for the coupling mounted in an assembly follow the respective test instructions for the equipment but do not exceed 1,5 x Working Pressure of the coupling.

STORAGE

Store coupling in a dry, dust free, dark place, in ambient temperature.

LUBRICANTS & OTHER

O-rings: Fluorflon® or equivalent.

Rollers and washers: Cargo Fluor® or equivalent.

Swivel sleeve thread: Bomfett® or equivalent.

Roller shaft: Loctite® 2700 or equivalent.